

# PCI8502 User's Manual

 **Beijing ART Technology Development Co., Ltd.**

## *Contents*

<i>Contents</i> .....	2
<i>Chapter 1 Overview</i> .....	3
<i>Chapter 2 Components Layout Diagram and a Brief Description</i> .....	5
2.1 The Main Component Layout Diagram .....	5
2.2 Block Diagram .....	6
2.3 The Function Description for the Main Component .....	6
2.4 The Trigger Signal Port .....	7
<i>Chapter 3 Connection Ways for Each Signal</i> .....	8
3.1 Analog Signal Connection .....	8
3.2 External Clock Input Signal Connection .....	8
3.3 ATR Trigger Signal Connection .....	8
3.4 DTR Trigger Signal Connection .....	8
3.5 Multiple-Instrument Synchronization .....	8
<i>Chapter 4 The Instruction of the Functions</i> .....	11
4.1 Trigger Source .....	11
4.2 Trigger Mode .....	12
4.2.1 Post-trigger Acquisition .....	12
4.2.2 Pre-trigger Acquisition .....	12
4.2.3 Middle-trigger Acquisition .....	13
4.2.4 Delay-trigger Acquisition .....	13
4.3 AD Internal Trigger Function .....	14
4.4 AD External Trigger Mode .....	14
4.4.1 ATR Trigger .....	14
4.4.2 DTR Trigger .....	16
<i>Chapter 5 Methods of using AD Internal and External Clock Function</i> .....	17
5.1 Internal Clock Function of AD .....	17
5.2 External Clock Function of AD .....	17
<i>Chapter 6 Notes, Calibration and Warranty Policy</i> .....	18
6.1 Notes .....	18
6.2 Auto-calibration .....	18
6.3 Warranty Policy .....	18
<b>Products Rapid Installation and Self-check</b> .....	<b>20</b>
Rapid Installation .....	20
Self-check .....	20
Delete Wrong Installation .....	20

## Chapter 1 Overview

In the fields of Real-time Signal Processing, Digital Image Processing and others, high-speed and high-precision data acquisition modules are demanded. ART PCI8502 data acquisition module, which brings in advantages of similar products that produced in china and other countries, is convenient for use, high cost and stable performance.

### Unpacking Checklist

Check the shipping carton for any damage. If the shipping carton and contents are damaged, notify the local dealer or sales for a replacement. Retain the shipping carton and packing material for inspection by the dealer.

Check for the following items in the package. If there are any missing items, contact your local dealer or sales.

- PCI8502Data Acquisition Board
- ART Disk
  - a) user's manual (pdf)
  - b) drive
  - c) catalog
- Warranty Card

### FEATURES

#### Analog Input

- Input Range:  $\pm 5V$ ,  $\pm 1V$  ( $\pm 500mV$ ,  $\pm 200mV$ ,  $\pm 100mV$  can be customized)
- 12-bit resolution
- Sampling Rate: up to 40MHz/ch
- Input Channels: 4 synchronous inputs
- Analog Input Mode: Single-ended input
- Data Read Mode: inquire and DMA mode
- Memory Size: 256MB (DDR2)
- The memory of each channel is 64MB
- Clock Source: internal clock, external clock (software selectable)
- Trigger Mode: middle trigger, post trigger, pre trigger and delay trigger
- Trigger Source: software, ATR, DTR, TRG0~TRG7 Trigger Signal (Multi-card Synchronization)
- Trigger Direction: falling edge, rising edge, falling and rising edge trigger
- Trigger Level: decided by the input range
- Analog Trigger Source (ATR): each analog input can be used as the analog trigger source
- Analog Trigger Source (ATR) Input Range: the trigger level can be calculated with the 12-bit resolution, please see the 'ATR Trigger'
- Trigger Source DTR Input Range: standard TTL level
- Auto-calibration
- Coupling Mode: DC, AC
- Analog Input Impedance:  $1M\Omega$  ( $50\Omega$  can be selected)
- Operating Temperature Range:  $0^{\circ}C \sim 50^{\circ}C$
- Storage Temperature Range:  $-20^{\circ}C \sim 70^{\circ}C$

**Other Features**

- Board Clock Oscillation: 40MHz
- Non-linear error:  $\pm 2$ LSB(Maximum)
- System Measurement Accuracy: 0.1%
- System Noise: 0.8LSBrms
- Harmonic Distortion (THD): -75.1 dB
- Signal to Noise Ratio (SNR): 57.2 dB
- Spurious Free Dynamic Range (SFDR): 79.3 dB
- Significant Bits (ENOB): 9.1
- 3db bandwidth, typically 25MHz, max 35MHz

Test Conditions: sampling frequency 40MS/s, using 200KHz sine wave, input the 95% of full scale amplitude.

- Dimension: 133mm (L) \* 110mm (W)

## Chapter 2 Components Layout Diagram and a Brief Description

### 2.1 The Main Component Layout Diagram



## 2.2 Block Diagram

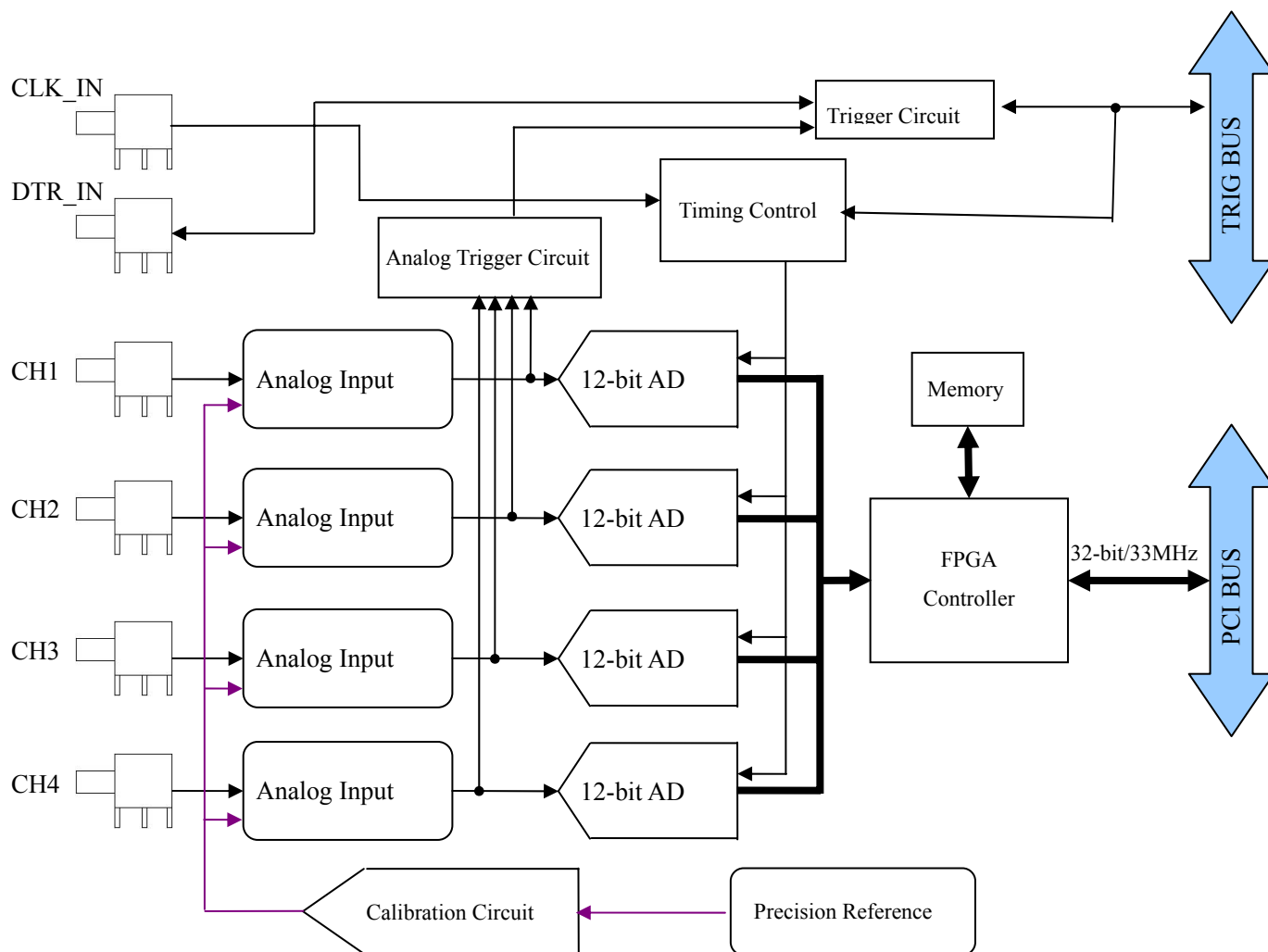

## 2.3 The Function Description for the Main Component

- J1 (CH1\_IN): AI0 analog input port
- J2 (CH2\_IN): AI1 analog input port
- J3 (CH3\_IN): AI2 analog input port
- J4 (CH4\_IN): AI3 analog input port
- J5: CLK\_IN (clock input port)
- J6: DTR\_IN (digital trigger signal input port)

## 2.4 The Trigger Signal Port

P2: 20-pin

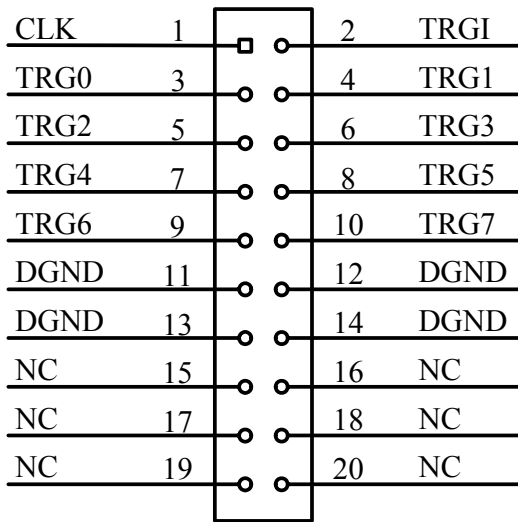

Pin name	Type	Pin function definition
TRG0~TRG7	Input/Output	Synchronization trigger signal
DGND	GND	Digital ground
CLK		NC
TRGI		NC
NC		NC

## Chapter 3 Connection Ways for Each Signal

### 3.1 Analog Signal Connection

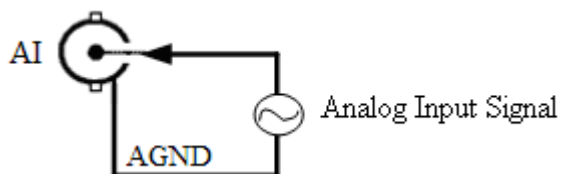

### 3.2 External Clock Input Signal Connection

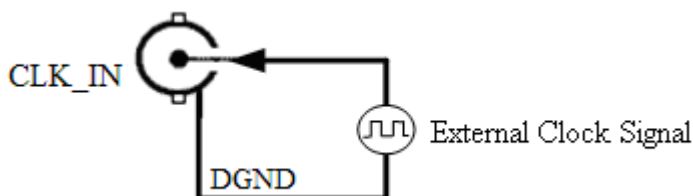

### 3.3 ATR Trigger Signal Connection

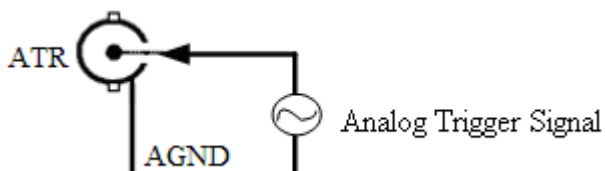

### 3.4 DTR Trigger Signal Connection

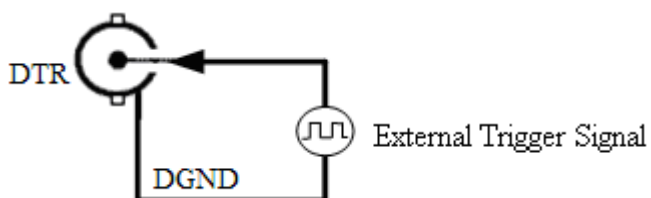

### 3.5 Multiple-Instrument Synchronization

Three methods can realize the synchronization for the PCI8502, the first method is using the Master-slave card cascade, the second one is using the common external trigger, and the last one is using the common external clock.



When using master-slave cascade card programs, the master card and slave card use the same TRG signal, general, the master card uses internal clock source, the slave card uses external clock source, after the master card, and slave card are initialized, first, start the all slave cards, because the main card has not been started, so there is no output clock signal, then the slave cards into a wait state until the master card is activated, at this time, all slave cards are started. Then we achieve synchronization data acquisition. See the following figure:

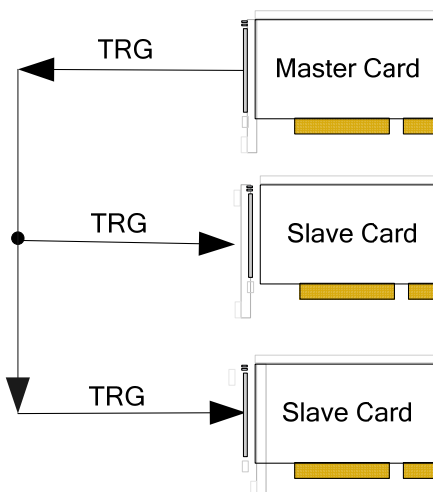

When you need to sample more than channels of a card, you could consider using the multi-card cascaded model to expand the number of channels.

When using the common external trigger, please make sure all parameters of different PCI8502 are the same. At first, configure hardware parameters, and use analog or digital signal triggering (ATR or DTR), then connect the signal that will be sampled by PCI8502, input triggering signal from ART pin or DTR pin, then click “Start Sampling” button, at this time, PCI8502 does not sample any signal but waits for external trigger signal. When each module is waiting for external trigger signal, use the common external trigger signal to startup modules, at last, we can realize synchronization data acquisition in this way. See the following figure:

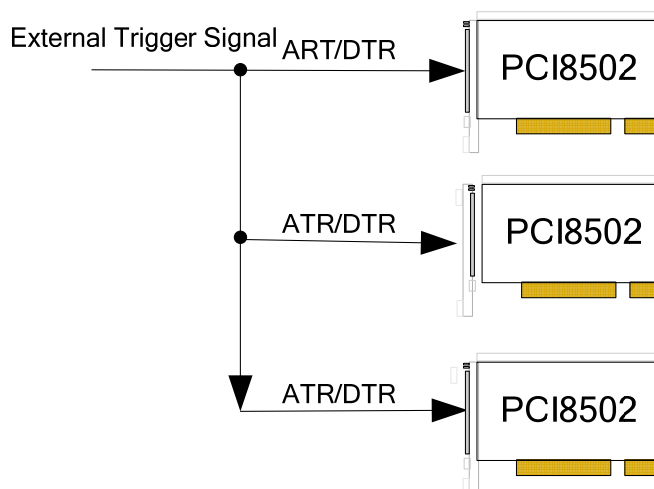

When using the common external clock trigger, please make sure all parameters of different PCI8502 are the same. At first, configure hardware parameters, and use external clock, then connect the signal that will be sampled by PCI8502, then click “Start Sampling” button, at this time, PCI8502 does not sample any signal, but wait for external clock signal. When each module is waiting for external clock signal, use the common external clock signal to startup modules, at last, we realize synchronization data acquisition in this way. See the following figure:

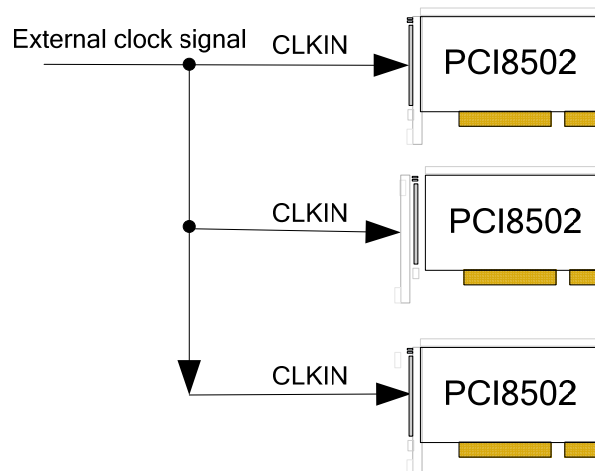

## Chapter 4 The Instruction of the Functions

### 4.1 Trigger Source

The PCI8502 support internal trigger source, external analog trigger, external digital trigger, TRG0 ~ TRG7 trigger. And we can set the trigger mode by the software. The following is the trigger diagram:

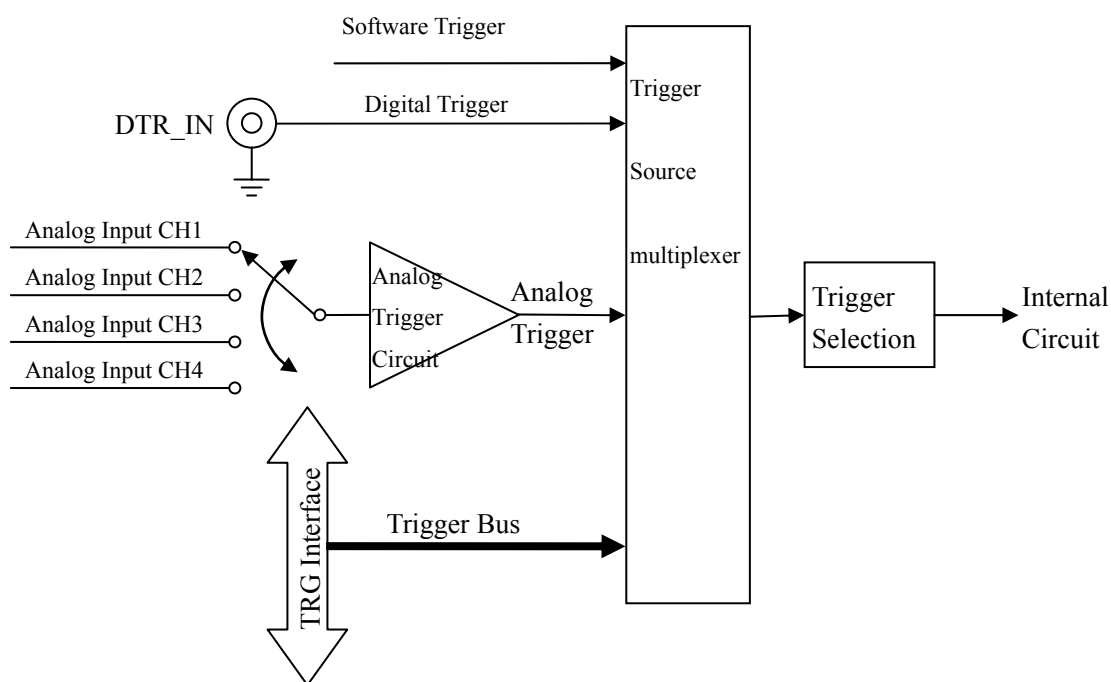

## 4.2 Trigger Mode

Middle trigger, post trigger, pre trigger and delay trigger modes are available to acquire data around the trigger event.

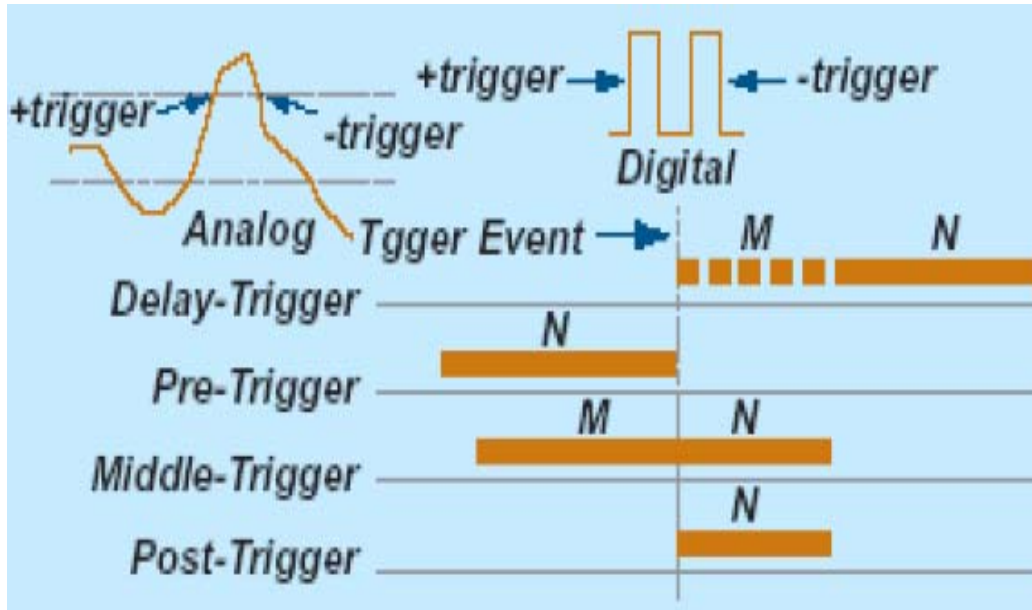

### 4.2.1 Post-trigger Acquisition

Use post-trigger acquisition when you want to collect data after the trigger event, as illustrated in figure.

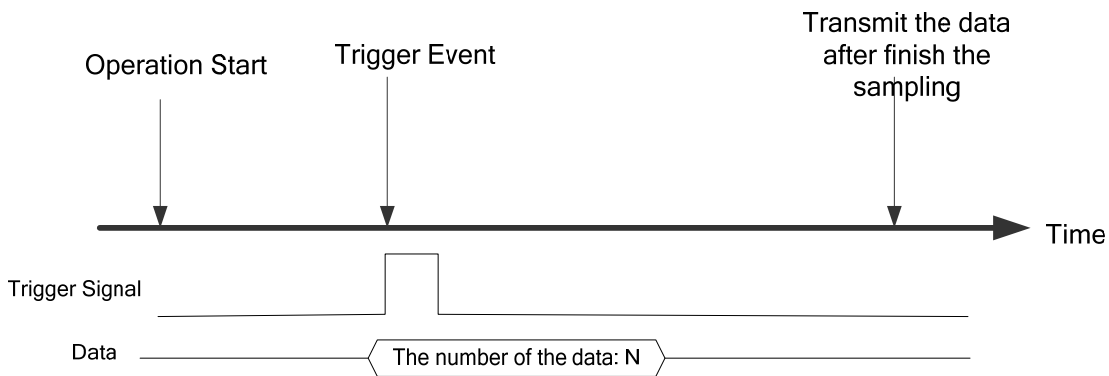

### 4.2.2 Pre-trigger Acquisition

Use pre-trigger acquisition to collect data before the trigger event. The acquisition starts once specified function calls are executed to begin the pre-trigger operation, and it stops when the trigger event occurs.

If the trigger event occurs after the specified amount of data has been acquired, the system only stores the data before the trigger event with the specified amount, as illustrated in Figure.

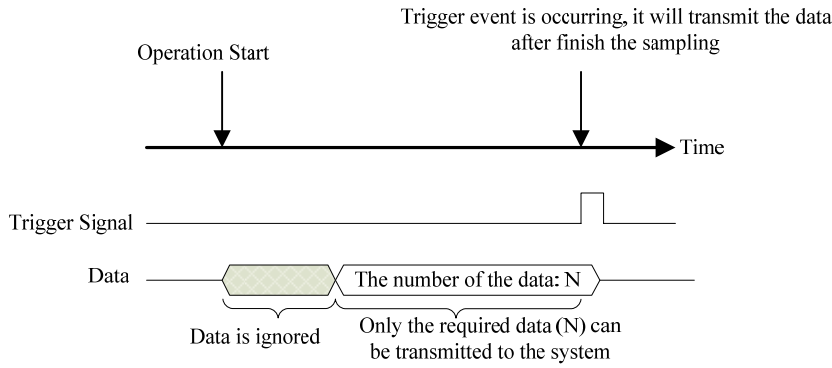

However, if the trigger event occurs before the specified amount of data has been acquired, the system can either stop the acquisition immediately (which implies the stored data will be less than the amount you specified) or ignore the trigger signal until the specified amount of data has been acquired (which assures the user can get the specified amount of data). These can be set by software and are illustrated in Figure.

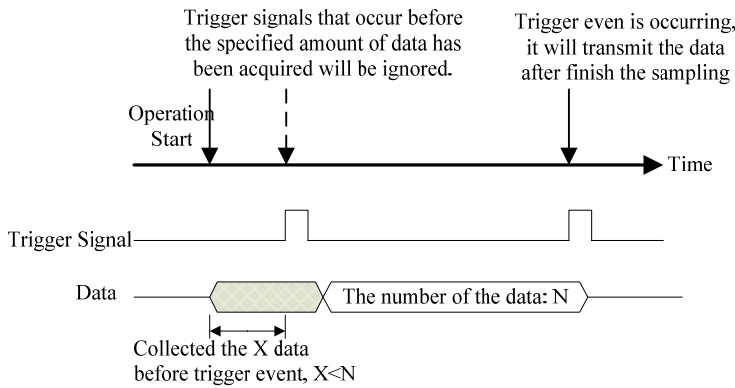

### 4.2.3 Middle-trigger Acquisition

Use middle-trigger acquisition when you want to collect data before and after the trigger event. The amount of stored data before and after the trigger can be set individually (M and N), as illustrated in Figure.

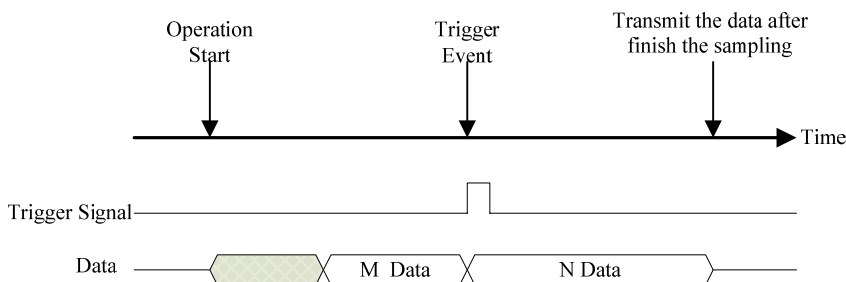

Like pre-trigger mode, the stored data may be less than the amount specified if the trigger event occurs before the specified amount of data (M) has been acquired. Users can also set by program to ignore trigger signals until the specified amount of data (M) has been acquired.

### 4.2.4 Delay-trigger Acquisition

Use delay trigger acquisition to delay the data collection after the trigger event, as illustrated in Figure 4.11. If the trigger

event starts, it will delay (M), then starts to acquire the data with the specified amount (N).

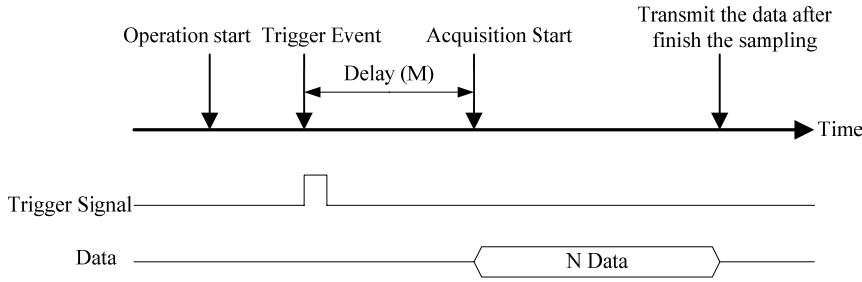

### 4.3 AD Internal Trigger Function

When AD is in the initialization, if the AD hardware parameter ADPara.TriggerMode = PCI8502\_TRIGMODE\_SOFT, we can achieve the internal trigger acquisition. In this function, when calling the StartDeviceProAD function, it will generate AD start pulse, AD immediately access to the conversion process and not wait for the conditions of any other external hardware. It also can be interpreted as the software trigger.

As for the specific process, please see the figure below, the cycle of the AD work pulse is decided by the sampling frequency.

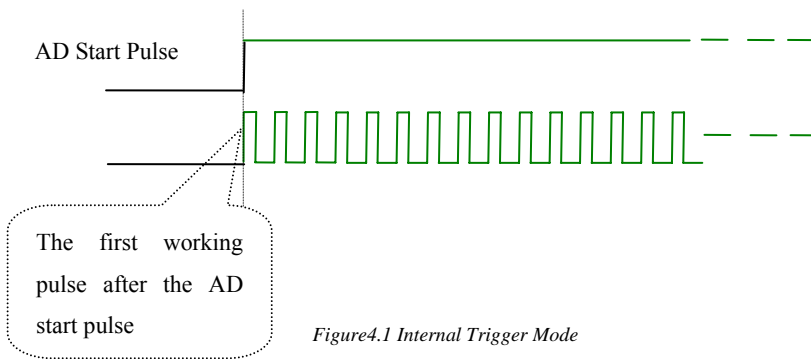

### 4.4 AD External Trigger Mode

When AD is in the initialization, if the AD hardware parameter ADPara.TriggerMode = PCI8502\_TRIGMODE\_POST, we can achieve the external trigger acquisition. In this function, when calling the StartDeviceProAD function, AD will not immediately access to the conversion process but wait for the external trigger source signals accord with the condition, then start converting the data. It also can be interpreted as the hardware trigger. Trigger source includes the DTR (Digital Trigger Source) and ATR (Analog Trigger Source).

#### 4.4.1 ATR Trigger

When the trigger signal is the analog signal, using the ATR trigger source. Trigger level needs to be set when using the ATR trigger source. There are two trigger types: edge trigger and level trigger

The trigger level can be calculated with the 12-bit resolution

Trigger Level Set (Hex)	Trigger Level (±5V)	Trigger Level (±1V)
0xFFF	4997.55mV	999.51mV
FFE	4995.11mV	999.02mV
.....	.....	.....
801	2.44mV	0.488mV
800	0V	0V
7FF	-2.44mV	-0.488mV
.....	.....	.....
001	-4995.11mV	-999.51mV

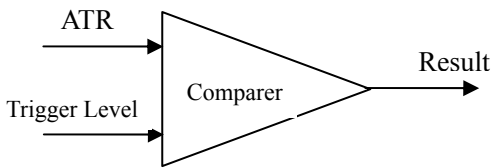

Figure 4.2 Analog compare

When ADPara.TriggerDir = PCI8502\_TRIGDIR\_NEGATIVE, choose the trigger mode as the falling edge trigger. That is, when the ATR trigger signal is on the falling edge, AD will immediately access to the conversion process, and its follow-up changes have no effect on AD acquisition.

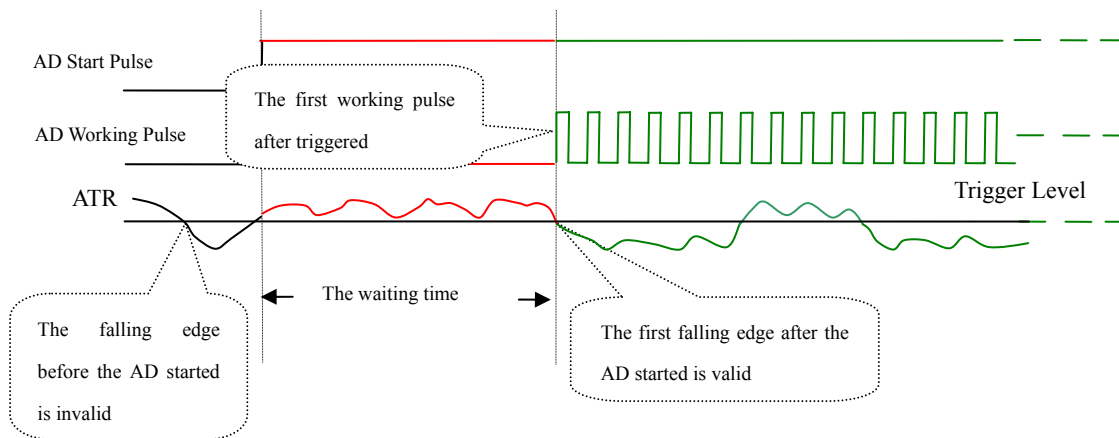

Figure 4.3 Falling edge Trigger

When ADPara.TriggerDir = PCI8502\_TRIGDIR\_POSITIVE, choose the trigger mode as rising edge trigger. That is, when the ATR trigger signal is on the rising edge, AD will immediately access to the conversion process, and its follow-up changes have no effect on AD acquisition.

When ADPara.TriggerDir = PCI8502\_TRIGDIR\_POSIT\_NEGAT, choose the trigger mode as rising or falling edge trigger. That is, when the ATR trigger signal is on the rising or falling edge, AD will immediately access to the conversion process, and its follow-up changes have no effect on AD acquisition. This function can be used in the case that the acquisition will occur if the exoteric signal changes.

### 4.2.2 DTR Trigger

When ADPara.TriggerDir = PCI8502\_TRIGDIR\_NEGATIVE, choose the trigger mode as the falling edge trigger. That is, when the DTR trigger signal is on the falling edge, AD will immediately access to the conversion process, and its follow-up changes have no effect on AD acquisition.

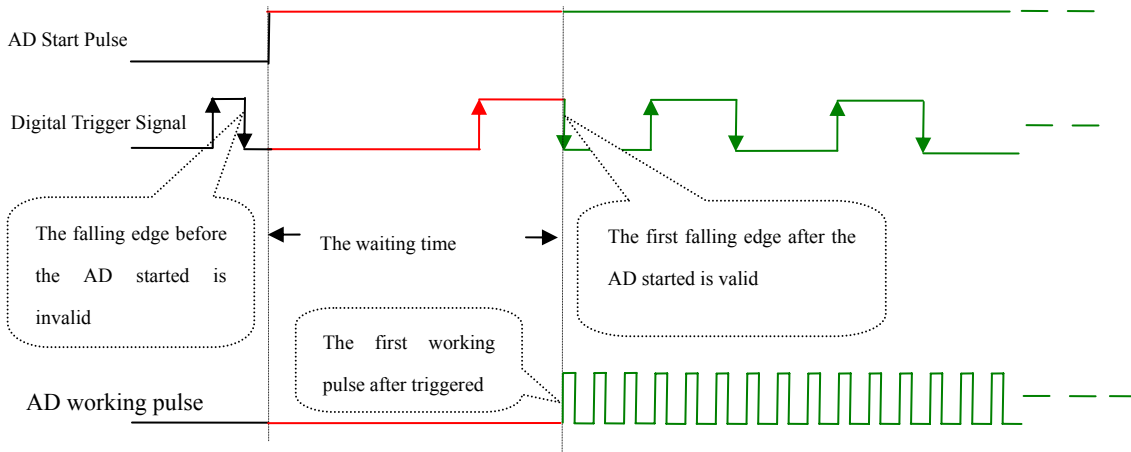

Figure 4.4 Falling edge Trigger

When ADPara.TriggerDir = PCI8502\_TRIGDIR\_POSITIVE, choose the trigger mode as rising edge trigger. That is, when the DTR trigger signal is on the rising edge, AD will immediately access to the conversion process, and its follow-up changes have no effect on AD acquisition.

When ADPara.TriggerDir = PCI8502\_TRIGDIR\_POSIT\_NEGAT, choose the trigger mode as rising or falling edge trigger. That is, when the DTR trigger signal is on the rising or falling edge, AD will immediately access to the conversion process, and its follow-up changes have no effect on AD acquisition. This function can be used in the case that the acquisition will occur if the exoteric signal changes.



## *Chapter 5 Methods of using AD Internal and External Clock Function*

### **5.1 Internal Clock Function of AD**

Internal Clock Function refers to the use of on-board clock oscillator and the clock signals which are produced by the user-specified frequency to trigger the AD conversion regularly. To use the clock function, the hardware parameters `ADPara.ClockSource = PCI8502_CLOCKSRC_IN` should be installed in the software. The frequency of the clock in the software depends on the hardware parameters `ADPara.Frequency`. For example, if `Frequency = 100000`, that means AD work frequency is 100000Hz (that is, 100 KHz, 10 us/point).

### **5.2 External Clock Function of AD**

External Clock Function refers to the use of the outside clock signals to trigger the AD conversion regularly. The clock signals are provide by the CLKOUT pin. The external clock can be provided by clock frequency generators and so on. To use the external clock function, the hardware parameters `ADPara.ClockSource = PCI8502_CLOCKSRC_OUT` should be set in the software. The clock frequency depends on the frequency of the external clock, and the clock frequency on-board is invalid, the sampling frequency of the AD is fully controlled by the external clock frequency.

## ***Chapter 6 Notes, Calibration and Warranty Policy***

### **6.1 Notes**

In our products' packing, user can find a user manual, a PCI8502 module and a quality guarantee card. Users must keep quality guarantee card carefully, if the products have some problems and need repairing, please send products together with quality guarantee card to ART, we will provide good after-sale service and solve the problem as quickly as we can. When using PCI8502, in order to prevent the IC (chip) from electrostatic harm, please do not touch IC (chip) in the front panel of PCI8502 module.

### **6.2 Auto-calibration**

By using the auto-calibration feature of the PCI8502, the calibration software can measure and correct almost all the calibration errors without any external signal connections, reference voltages, or measurement de-vices.

Automatic calibration is complete, the calibration constants are stored in EEPROM. The default calibration constants are stored in fixed storage area.

Time and temperature will affect the error, so when install PCI8502 in the new environment, we should recalibrate it.

NOTE: before auto-calibration procedure starts, it is recommended to warm up the card for at least 15 minutes. Do not connect the external signal to the PCI8504, and remove the signal cable that connects with the SMB interface.

### **6.3 Warranty Policy**

Thank you for choosing ART. To understand your rights and enjoy all the after-sales services we offer, please read the following carefully.

1. Before using ART's products please read the user manual and follow the instructions exactly. When sending in damaged products for repair, please attach an RMA application form which can be downloaded from: [www.art-control.com](http://www.art-control.com).
2. All ART products come with a limited two-year warranty:
  - The warranty period starts on the day the product is shipped from ART's factory
  - For products containing storage devices (hard drives, flash cards, etc.), please back up your data before sending them for repair. ART is not responsible for any loss of data.
  - Please ensure the use of properly licensed software with our systems. ART does not condone the use of pirated software and will not service systems using such software. ART will not be held legally responsible for products shipped with unlicensed software installed by the user.
3. Our repair service is not covered by ART's guarantee in the following situations:
  - Damage caused by not following instructions in the User's Manual.
  - Damage caused by carelessness on the user's part during product transportation.
  - Damage caused by unsuitable storage environments (i.e. high temperatures, high humidity, or volatile chemicals).
  - Damage from improper repair by unauthorized ART technicians.

- Products with altered and/or damaged serial numbers are not entitled to our service.
4. Customers are responsible for shipping costs to transport damaged products to our company or sales office.
  5. To ensure the speed and quality of product repair, please download an RMA application form from our company website.

# Products Rapid Installation and Self-check

## Rapid Installation

Product-driven procedure is the operating system adaptive installation mode. After inserting the disc, you can select the appropriate board type on the pop-up interface, click the button **【driver installation】** ; or select CD-ROM drive in Resource Explorer, locate the product catalog and enter into the APP folder, and implement Setup.exe file. After the installation, pop-up CD-ROM, shut off your computer, insert the PCI card. If it is a USB product, it can be directly inserted into the device. When the system prompts that it finds a new hardware, you do not specify a drive path, the operating system can automatically look up it from the system directory, and then you can complete the installation.

## Self-check

At this moment, there should be installation information of the installed device in the Device Manager (when the device does not work, you can check this item.). Open "Start -> Programs -> ART Demonstration Monitoring and Control System -> Corresponding Board -> Advanced Testing Presentation System", the program is a standard testing procedure. Based on the specification of Pin definition, connect the signal acquisition data and test whether AD is normal or not. Connect the input pins to the corresponding output pins and use the testing procedure to test whether the switch is normal or not.

## Delete Wrong Installation

When you select the wrong drive, or viruses lead to driver error, you can carry out the following operations: In Resource Explorer, open CD-ROM drive, run Others-> SUPPORT-> PCI.bat procedures, and delete the hardware information that relevant to our boards, and then carry out the process of section I all over again, we can complete the new installation.